

NOBLE ACTIVE SUBWOOFER SUB10

OWNER'S MANUAL

THE PURE SOUND OF LIFE
PURE ACOUSTICS



Pure Acoustics, Inc. 18 Fuller Place, Brooklyn,
NY 11215, USA, Tel 718 788 4411

www.pure-acoustics.com

INTRODUCTION

Thank you for purchasing Pure Acoustics' products, and welcome to the Pure Acoustics family of satisfied customers!

Pure Acoustics was established to fulfill the need for high quality speakers of exceptional design at an affordable price. After years of research and development, and by manufacturing all parts ourselves – from the voice-coil to the uniquely-designed crossover -- Pure Acoustics is able to offer you speakers of superior value.

Each subwoofer component has been designed and engineered with first-rate materials to produce exceptional sound. The sleek cabinetry encases a deceptively powerful woofer that delivers a clear, open bass with incredibly low distortion, even at high volumes. This subwoofer offers the best of it all – high-quality sound, hand-made solid construction, and a remarkably stylish appearance.

We welcome you to witness the results. Our team's dedication to quality, reliability and attractive design has created some of the best-value subwoofers you can find today.

Reading this manual fully (the complete manual) will help you to set up your subwoofer properly and reward you with a fine listening experience. Pure Acoustics distribution centers in Europe, Asia, Australia and the Americas will be happy to assist you with any questions you may have. Please look for the distributor nearest you on our web site, www.pure-acoustics.com.

CONNECTIONS

Before you start, make sure all your equipment is switched off and the amplifier volume is on low. Make sure the positive (+) and negative (-) are connected to the appropriate terminal.

SUBWOOFER LOW-LEVEL CONNECTIONS

Using an RCA cable, connect the Pre Out (subwoofer) on your receiver to a Y connector. Then connect the Y Connector to the RCA Line in on your subwoofer.

SUBWOOFER HI-LEVEL CONNECTIONS

Connect a speaker wire from your amplifier's positive (+) output-left speaker terminal to the subwoofer's positive (+) input-left terminal. Connect another speaker wire from your amplifier's negative (-) output-left speaker terminal to the subwoofer's negative (-) left-input terminal. Connect a speaker wire from the positive (+) output-left speaker terminal on the subwoofer to the positive (+) input terminal on the front-left speaker. Connect another speaker cable from the negative (-) output-left speaker terminal on the to the negative (-) input terminal on the front left speaker. Repeat the same step for the right-side front speaker.

Make sure the subwoofer switch is in the OFF position, rotate the GAIN control to MIN and set the FREQ control to the middle position. Plug in the AC power cord to your electrical outlet. Turn on your amplifier and subwoofer and play your favorite music. Gradually increase your amplifier's volume to your desired level. Gradually increase your subwoofer GAIN level to your desired bass level. Adjust the FREQ control to a point where the subwoofer and rear speakers perform to your satisfaction. Toggle the PHASE switch between the REV and NOR positions to see which one sounds better to you. These adjustments are used to match the subwoofer bass reproduction with that of your main speakers. You can now leave the AUTO/ON/OFF switch in the AUTO position. This position is voice-activated; your subwoofer will switch on automatically only when the subwoofer receives an audio signal from your amplifier.

For optimal results, try a few different types of music.

POSITION

The subwoofer can be positioned anywhere in the room; for the best result, position it between the rear speakers or within 15ft (5m) of the main speakers. It is best to try the subwoofer in a few places around the room and check which one gives you the best listening experience. To avoid unnecessary vibrations, place the subwoofer on a solid surface.

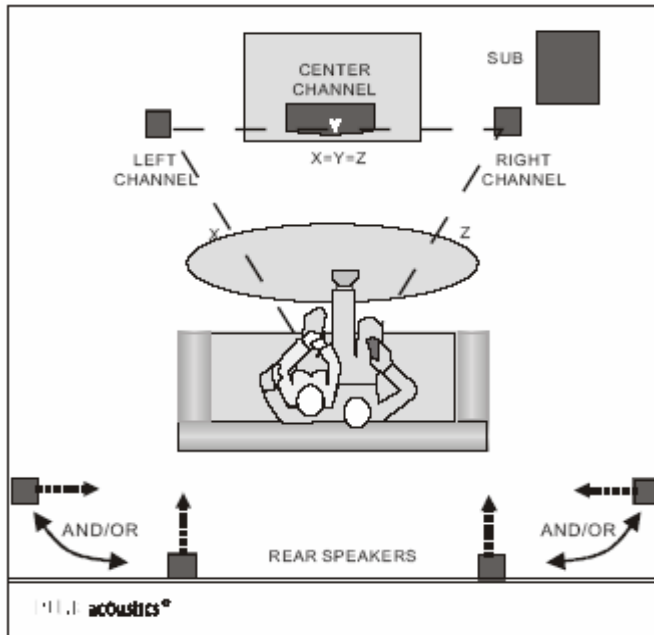

Set-Up Diagram

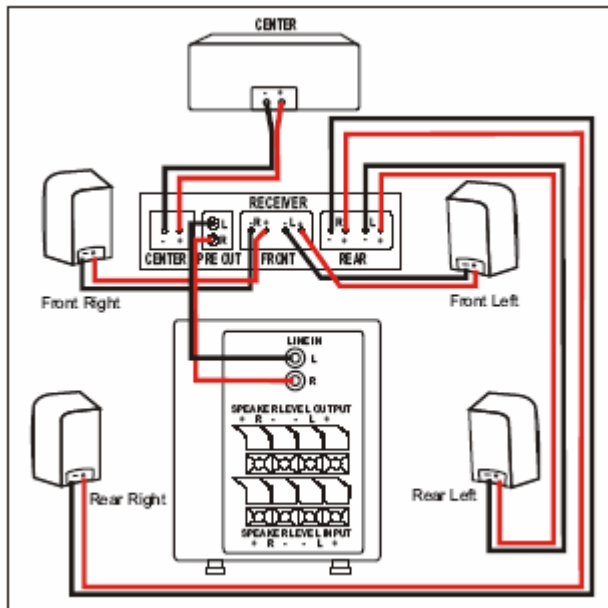

Low-level Connections

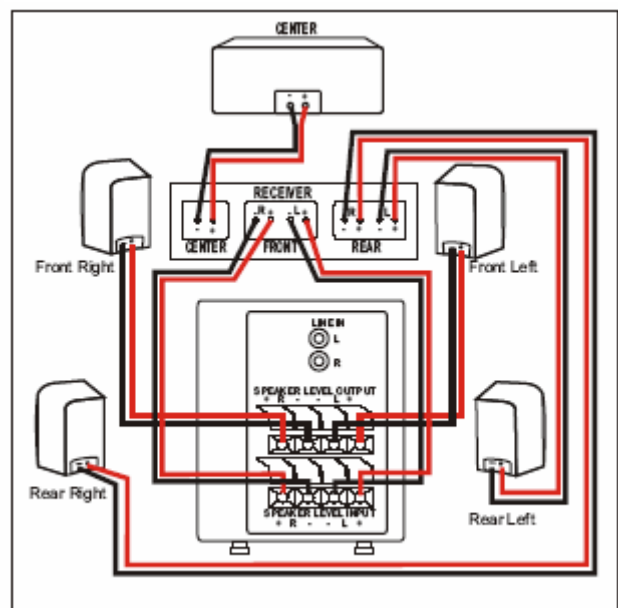

Hi-level Connections

RUNNING TIME AND CLEANING

The performance of the speakers may change during the initial use due to storage and mechanical limitations. Please allow 15 hours of use for the temperature effect and mechanical parts to attain their intended design characteristics.

Make sure to unplug the subwoofer from the wall before cleaning. The cabinet only requires occasional dusting. Please avoid touching the drive units.

LIMITED ONE-YEAR WARRANTY

Pure Acoustics products have been designed and manufactured to the highest quality standards. However, in the event that something malfunctions, Pure Acoustics and your local authorized distributor warrant free of charge parts and labor (some exclusions may apply) for a period of one year. This warranty is only valid for the original owner. This warranty is limited to the repair of the product. This warranty will not apply to units that were subject to misuse, neglect, abuse, alteration or improper installation. This warranty will not cover damage due to fire, water, heat, lightning or any other cause beyond the control of Pure Acoustics. Retention of your original dated receipt is required in order to obtain warranty service from your local authorized Pure Acoustics Dealer.

TECHNICAL SPECIFICATIONS

	Noble SUB
POWER HANDLING	150 Watts
FREQUENCY RESPONSE	35 Hz – 150 Hz adjustable
PHASE ALIGNMENT	0-180
IMPEDENCE	110 – 120 Volts
AUTO ON/OFF SWITCH	Yes
VOLUME CONTROL	Yes
LINE INPUT	RCA connector
SPEAKER INPUT/ OUTPUT	Low level / High level
DIMENSIONS (H X W X D)	37x36x33 Cm (14.5x14x13 In)
FINISH	Black, White
GRILLE	Black

Design and specifications are subject to change without notice.



Pure Acoustics, Inc. 18 Fuller Place Brooklyn, NY 11215
USA 718.788.4411

www.pure-acoustics.com